

## 24-INCH CHARCOAL GRILL

PARRILLA DE CARBÓN DE 24 PULGADAS

GRIL À CHARBON DE 24 POUÇES

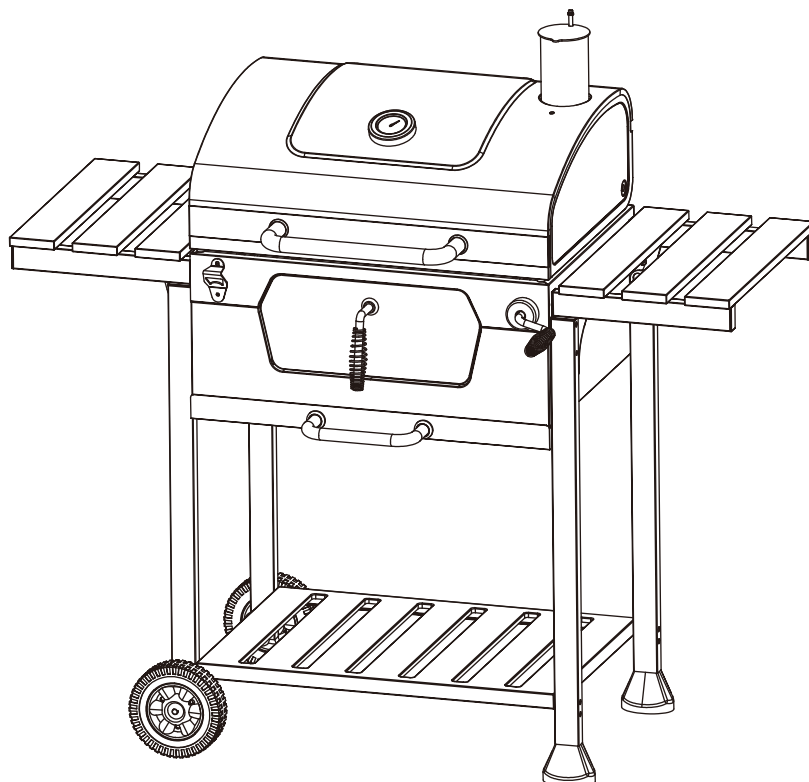

### FOR YOUR SAFETY! | ¡PARA SU SEGURIDAD! | POUR VOTRE SÉCURITÉ!

Use outdoors only!  
Read the instructions before  
assembling and using the appliance.

¡Solo usa al aire libre!  
Lea las instrucciones antes  
de montar y utilizar el aparato.

Utilisez uniquement à l'extérieur!  
Lisez les instructions avant  
d'assembler et d'utiliser l'appareil.

### CONTACT US FIRST! | ¡PÓNGASE EN CONTACTO CON NOSOTROS PRIMERO! | CONTACTEZ-NOUS D'ABORD!

If you have any questions that are  
not addressed, please contact us first.

Si tiene alguna pregunta que no se  
aborde en este Manual del Usuario,  
póngase en contacto con nosotros primero.

Si vous avez des questions qui ne  
sont pas traitées dans ce manuel de  
l'utilisateur, contactez-nous d'abord.



Customer Service / Servicio al Cliente / Service de Clientèle

☎ 1-800-618-6798









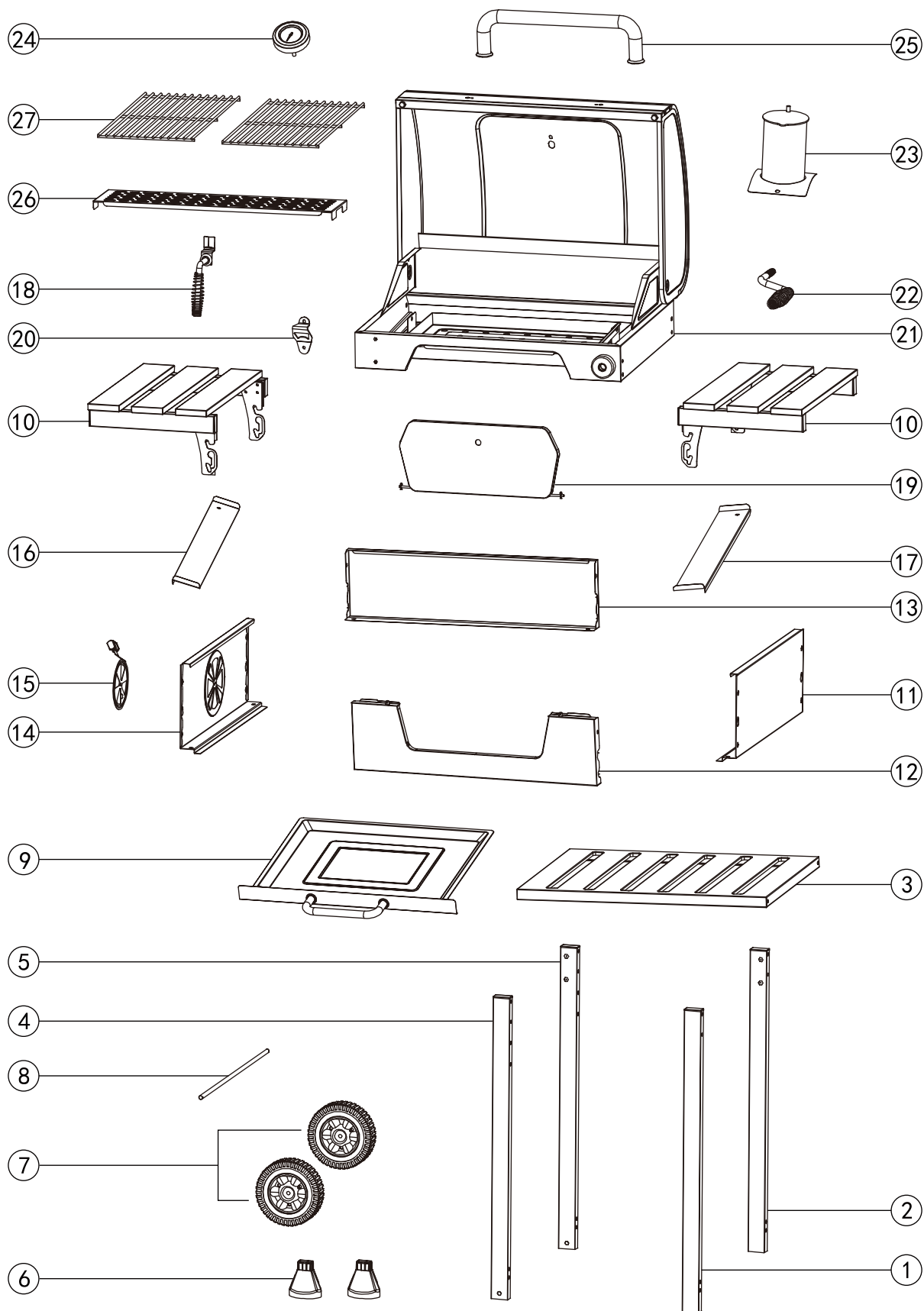





✉ service@royalgourmetusa.com



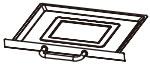

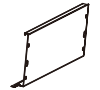

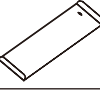
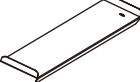

Learn more at / Obtener más información en / Pour en savoir plus:









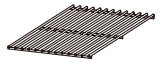

[www.royalgourmetcorp.com](http://www.royalgourmetcorp.com)



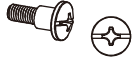

No.	#	QYT / CANT. / QTÉ	Description / Descripción / Description	Image / Imagen / Image
1	ECJ15JGRF	1	Right front leg Pata delantera derecha Pied avant droit	
2	ECJ15JGRB	1	Right back leg Pata trasera derecha Pied arrière droit	
3	ECJ15ADB	1	Bottom shelf Estante inferior Étagère inférieure	
4	ECJ15JGLF	1	Left front leg Pata delantera izquierda Pied avant gauche	
5	ECJ15JGLB	1	Left back leg Pata trasera izquierda Pied arrière gauche	
6	JS203	2	Leg base Pata base Base de pied	
7	LZ100	2	Wheel Rueda Roue	
8	LZ004-CA	1	Wheel axle Eje de rueda Essieu de roue	
9	ELTTIXJHP	1	Ash tray Cenicero Bac à cendres	
10	EHCTY	2	Side table Mesa lateral Table d'appoint	
11	ELTTIXCBR	1	Right panel Panel derecho Panneau droit	
12	EHLTTIXQB	1	Front panel Panel frontal Panneau avant	
13	ELTTIXHB	1	Rear panel Panel trasero Panneau arrière	
14	ELTTIXCBL	1	Left panel Panel izquierdo Panneau gauche	
15	W-ZH300101+ Z-ZH2302030	1	Damper Regulador de tiro Amortisseur	
16	EHLTT1DYPL	1	Grease deflector (L) Deflector de Grasa (I) Déflecteur de graisse (G)	
17	EHLTT1DYPR	1	Grease deflector (R) Deflector de Grasa (D) Déflecteur de graisse (D)	

No.	#	QYT / CANT. / QTÉ	Description / Descripción / Description	Image / Imagen / Image
18	W-R3003	1	Door handle Manija de puerta Poignée de porte	
19	EHTM	1	Charcoal access door Puerta de acceso del carbón Porte d'accès au charbon	
20	KQ001 (W-DXL12012)	1	Bottle opener Abridor de botella Ouvre-bouteille	
21		1	Main body Cuerpo principal Corps principal	
22	YZ002	1	Crank handle Manivela Manivelle	
23	EHSG13YC	1	Stack Chimenea Cheminée	
24	WJ201 (W-20130020)	1	Thermometer Termómetro Thermomètre	
25	SS201	1	Lid handle Manija de la tapa Poignée du couvercle	
26	ELT1BWW3B	1	Warming rack Rejilla para calentar Grille de réchauffement	
27	W-CD1824020	2	Cooking grate Rejilla para asar Grille de cuisson	

Key / Clave / Réf.	Description / Descripción / Description	QTY / CANT. / QTÉ	Image / Imagen / Image
A	M5x55	12	
B	M5x10	8	
C	M4x15	4	
D	Split pin Pasador partido Goupille fendue	2	
E	Washer Arandela Rondelle	2	
F	M6	2	
G	M6x15	4	
H	M6x20	8	
I	M5	1	
J	M5	1	
K	M4x10	2	
L	M5x12	1	

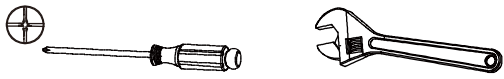
TOOLS REQUIRED / HERRAMIENTAS REQUERIDAS / OUTILS REQUIS		
Description / Descripción / Description		Image / Imagen / Image
Phillips screwdriver Destornillador phillips Tournevis phillips	Wrench Llave Clé	

Before beginning assembly, make sure all parts are present. If any parts are missing or damaged, do not attempt to assemble the products. Contact customer service for replacement parts via telephone or email.

- Tools needed (not included): Phillips screwdriver and wrench
- Approximate assembly time: 50 minutes
- Note: 1. The right and left sides of the grill are designed as if you are facing the front of the grill.  
2. Model shown for illustration purpose only, specific please in kind prevail.

Antes de comenzar el montaje, asegúrese de que todas las piezas estén presentes. Si falta alguna pieza o está dañada, no intente ensamblar los productos. Póngase en contacto con el servicio de atención al cliente para obtener piezas de repuesto por teléfono o correo electrónico.

- Herramienta necesaria (no incluido): Destornillador phillips y llave
- Tiempo aproximado de ensamblaje: 50 minutos
- Nota: 1. Los lados derecho e izquierdo de la parrilla están diseñados como si estuvieras frente a la parte delantera de la parrilla.  
2. El modelo que se muestra es sólo para fines ilustrativos, prevalecen los específicos en especie.

Avant de commencer l'assemblage, assurez-vous que toutes les pièces sont présentes. Si des pièces sont manquantes ou endommagées, n'essayez pas d'assembler les produits. Contactez le service de clientèle pour les pièces de rechange par téléphone ou par e-mail.

- Outils nécessaires (non inclus): Tournevis phillips et clé
- Temps nécessaire pour l'assemblage: 50 minutes
- Remarque: 1. Les côtés droit et gauche du gril sont concus comme si vous faisiez face à l'avant du gril.  
2. Le modèle est présenté à des fins d'illustration uniquement, spécifiques en nature prévalent.

1

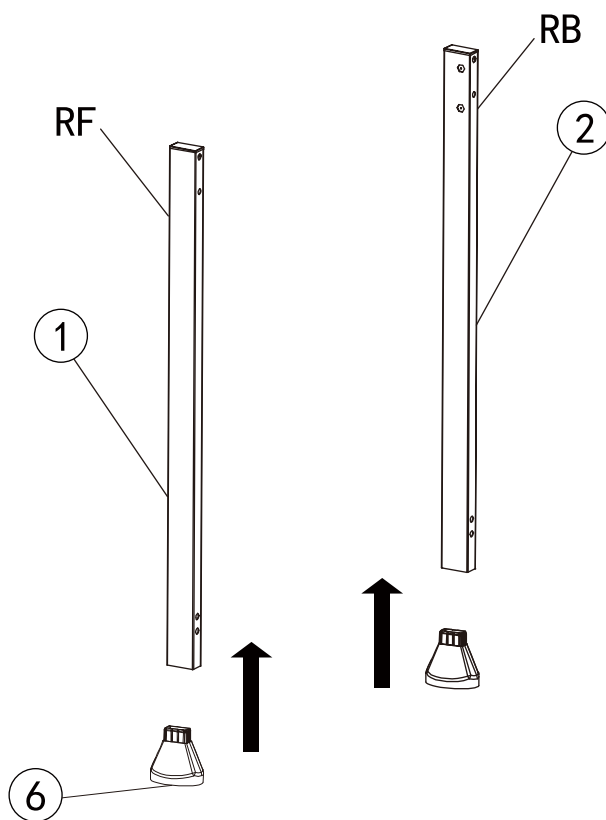

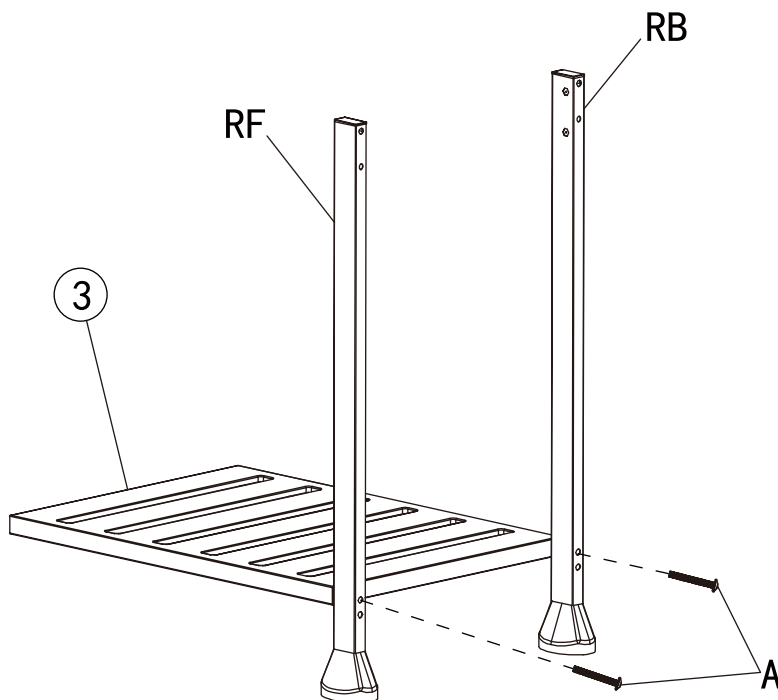

2



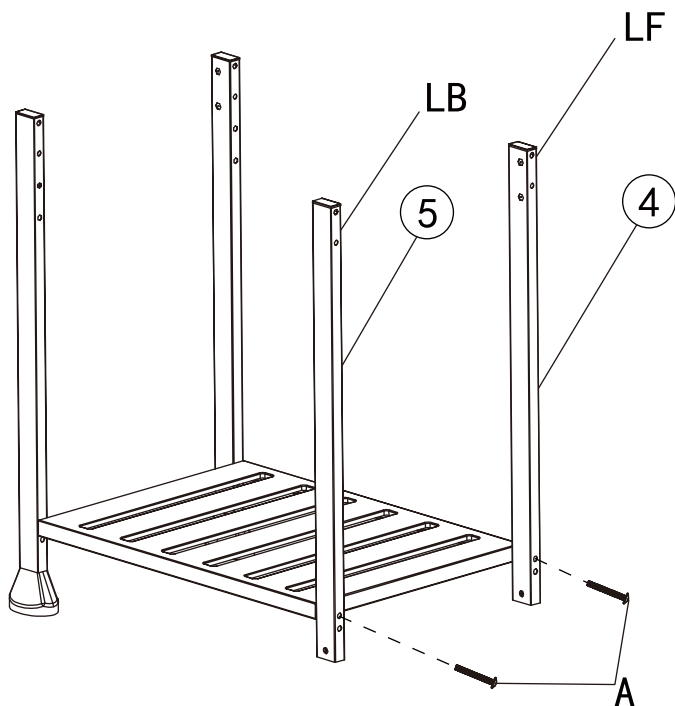

3	A		×2
---	---	---	----

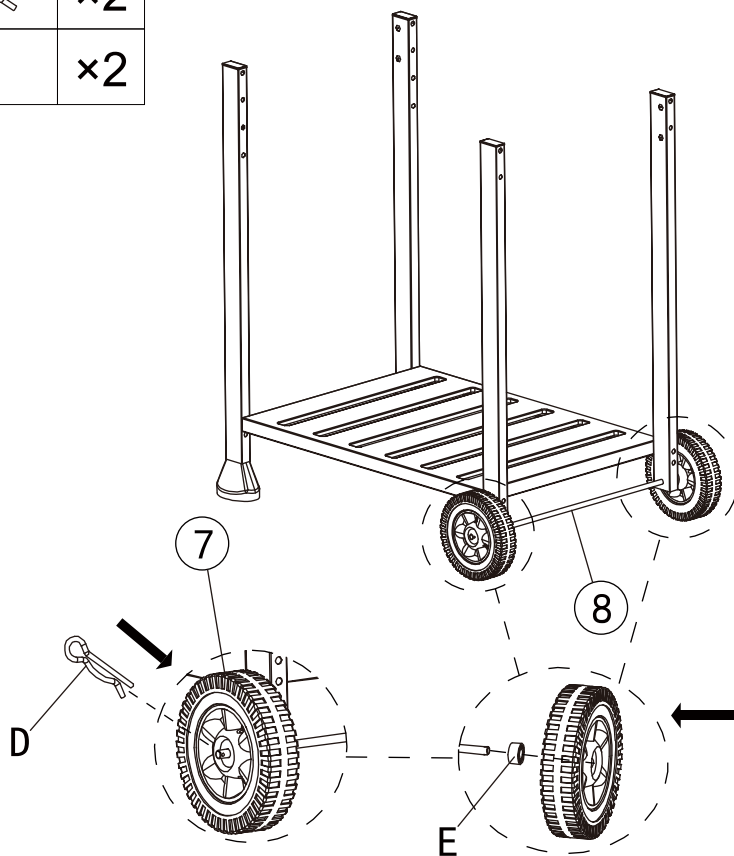

4	D		×2
	E		×2





<b>5</b>	I		×1
	J		×1
	L		×1

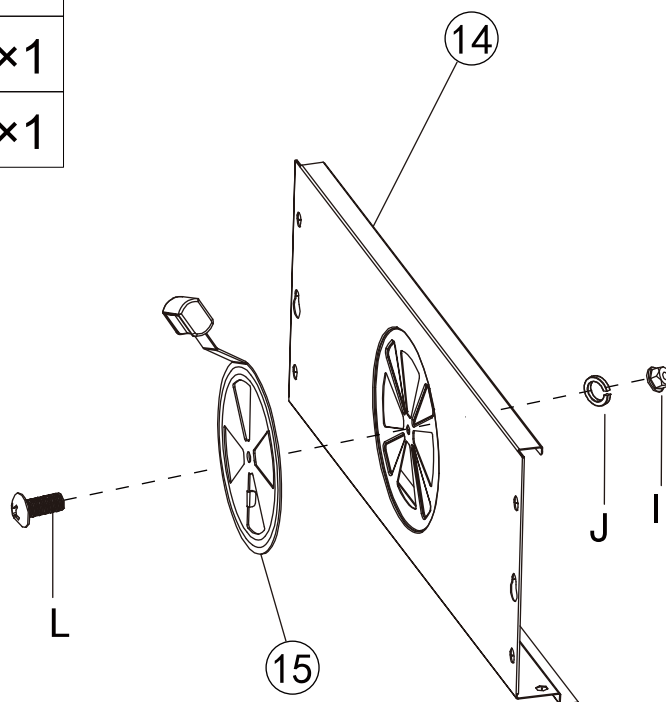

<b>6</b>	B		×4
----------	---	---	----

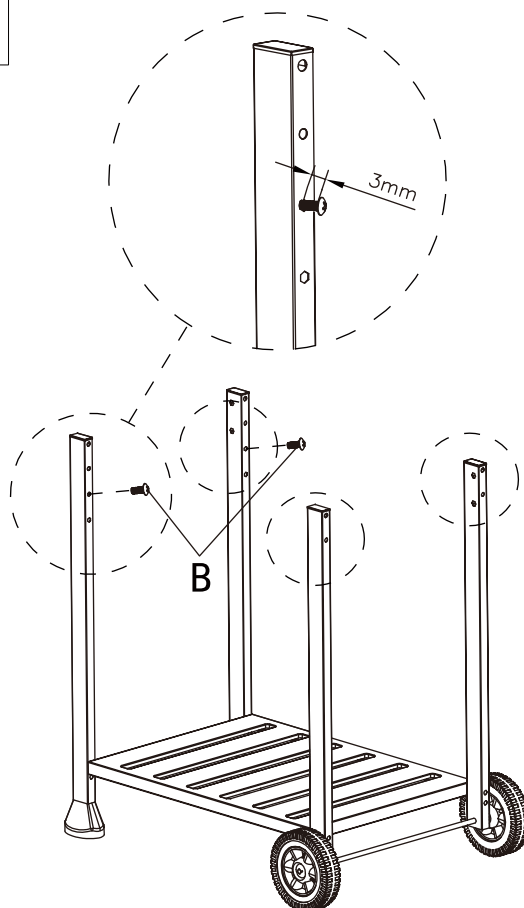

7

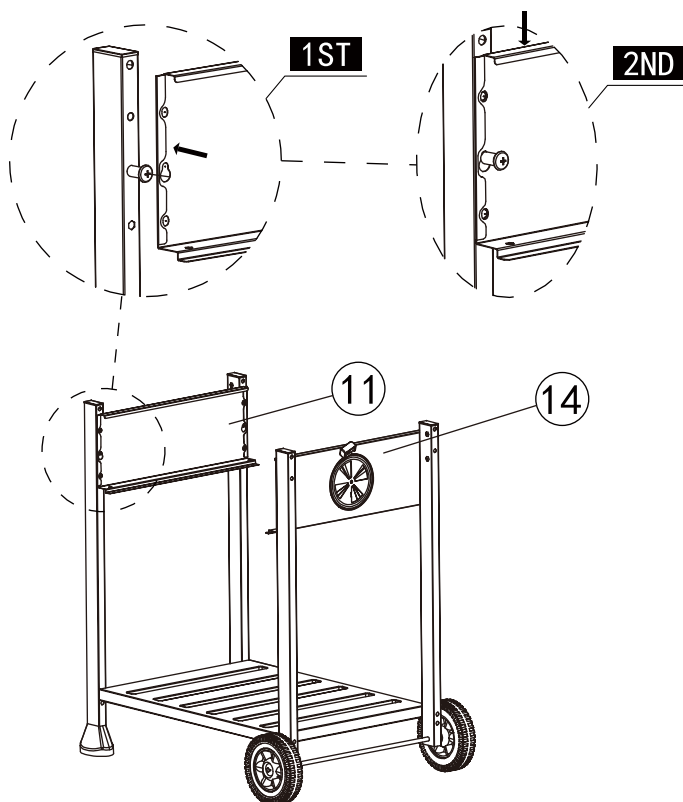

8 B  ×4

- Repeat for the other panel.
- Repita esto paso para el otro lado.
- Répéter le étape pour l'autre côté.

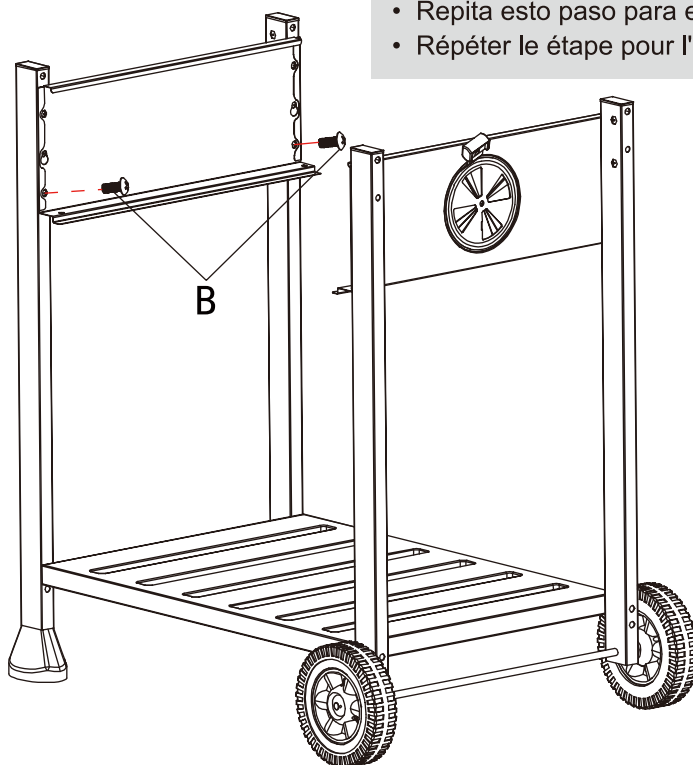

9 A  ×4

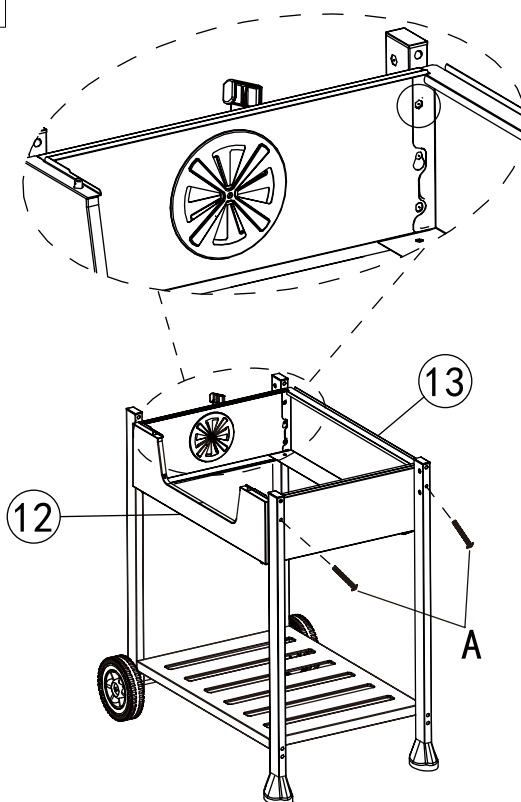

10 C  ×4

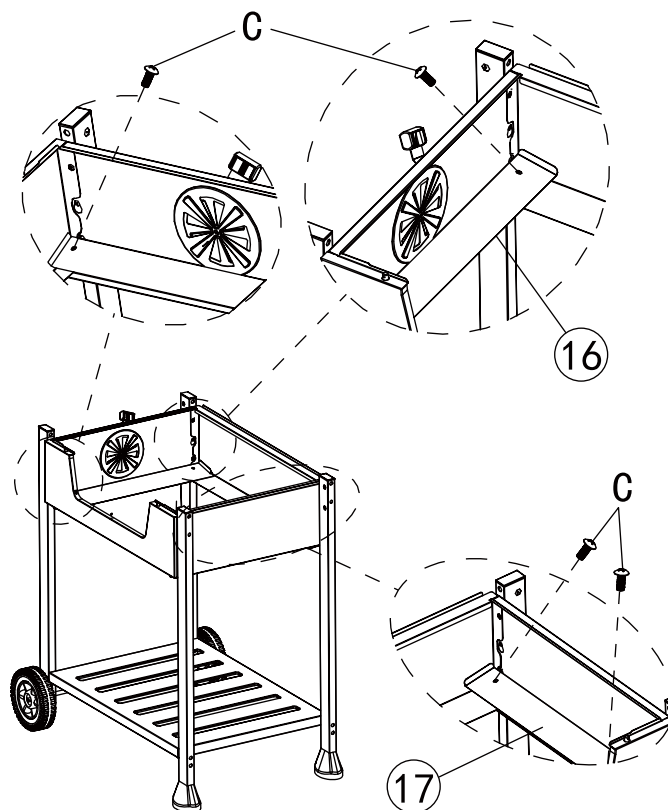

11

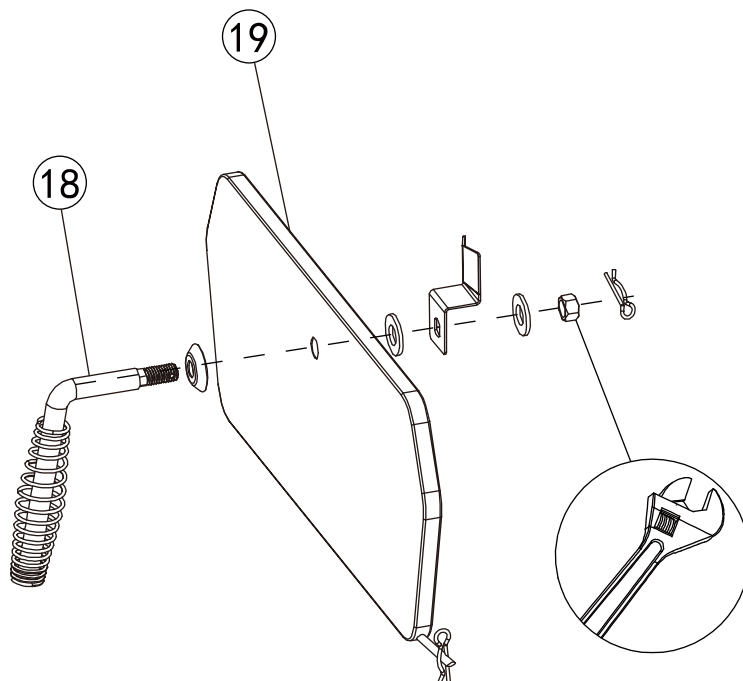

12

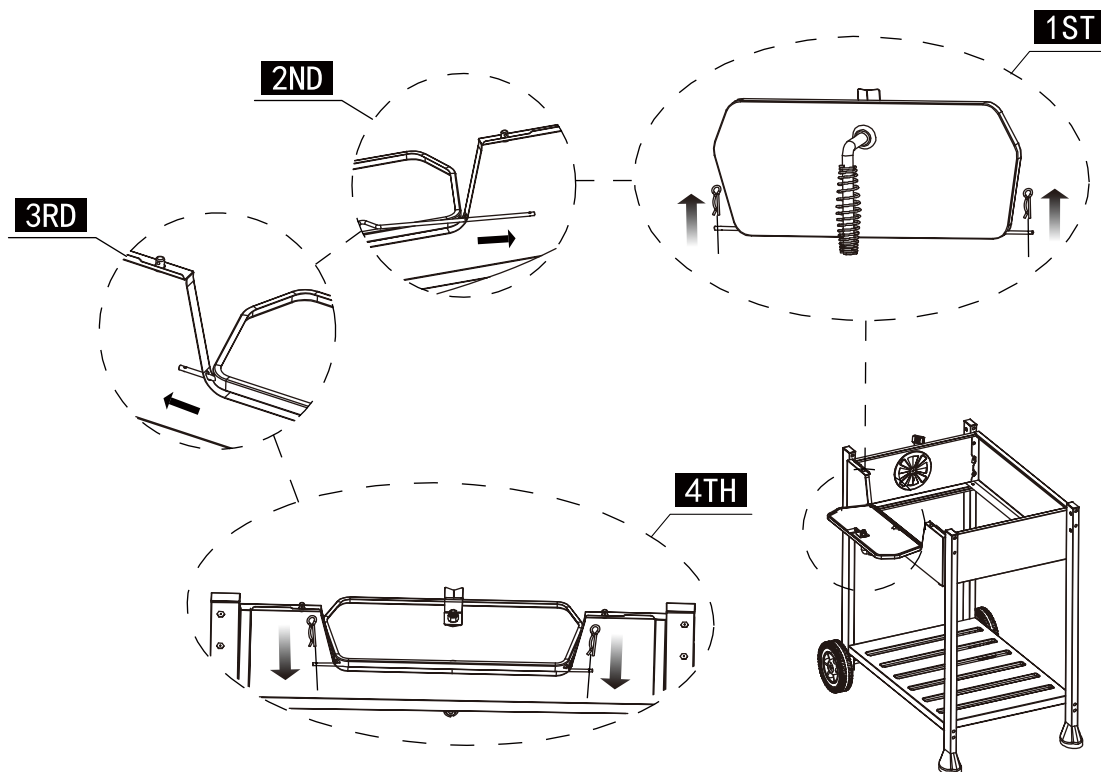

13 K  ⊕ ×2

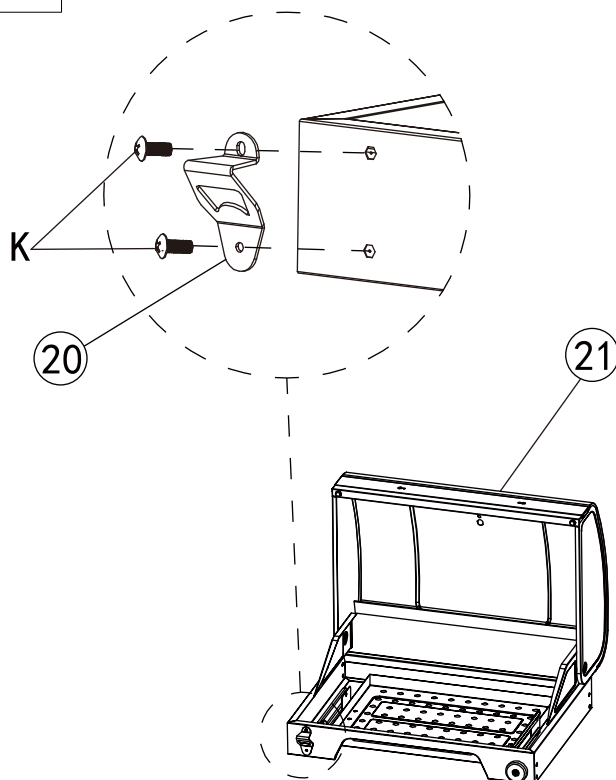

14

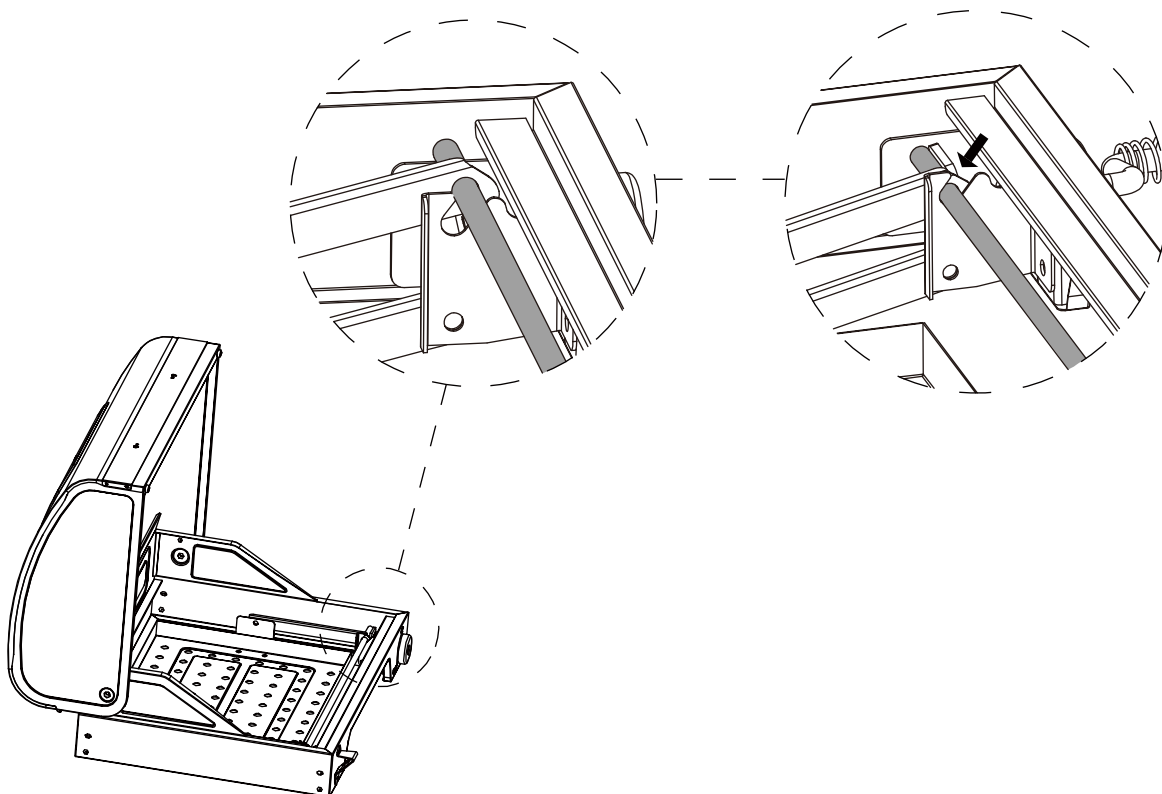

15

- Raise charcoal pan higher so as to secure crank.
- Levante primero la bandeja de charcaol y luego fije la manivela.
- Relevez d'abord le bac à charbon, puis fixez la manivelle.

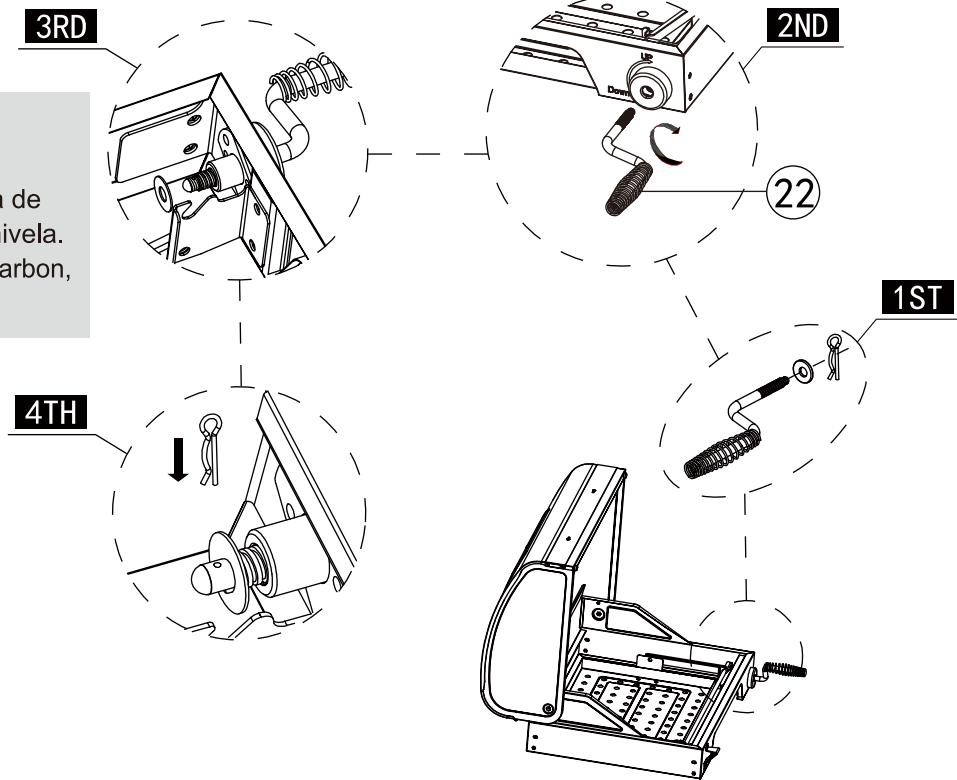

16

- Turn the crank to adjust the height of charcoal pan as needed.
- La bandeja de carbón se puede ajustar a la altura que necesite.
- Le bac à charbon peut être ajusté à la hauteur selon vos besoins.

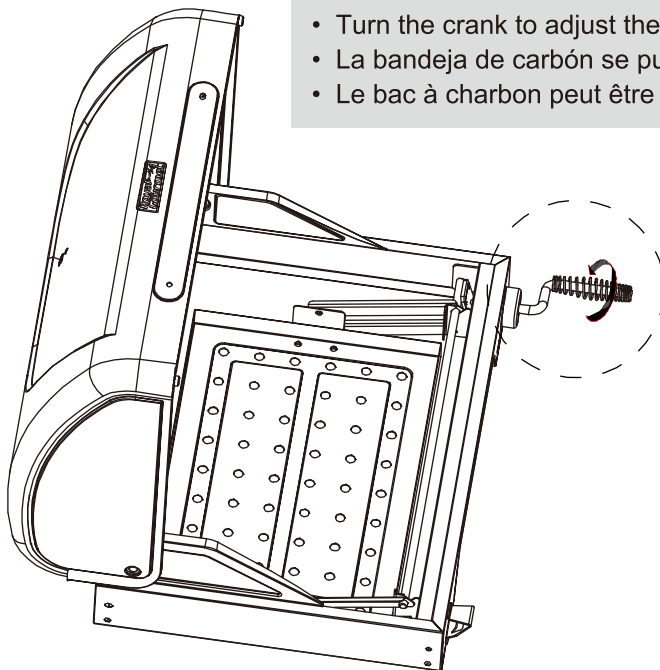

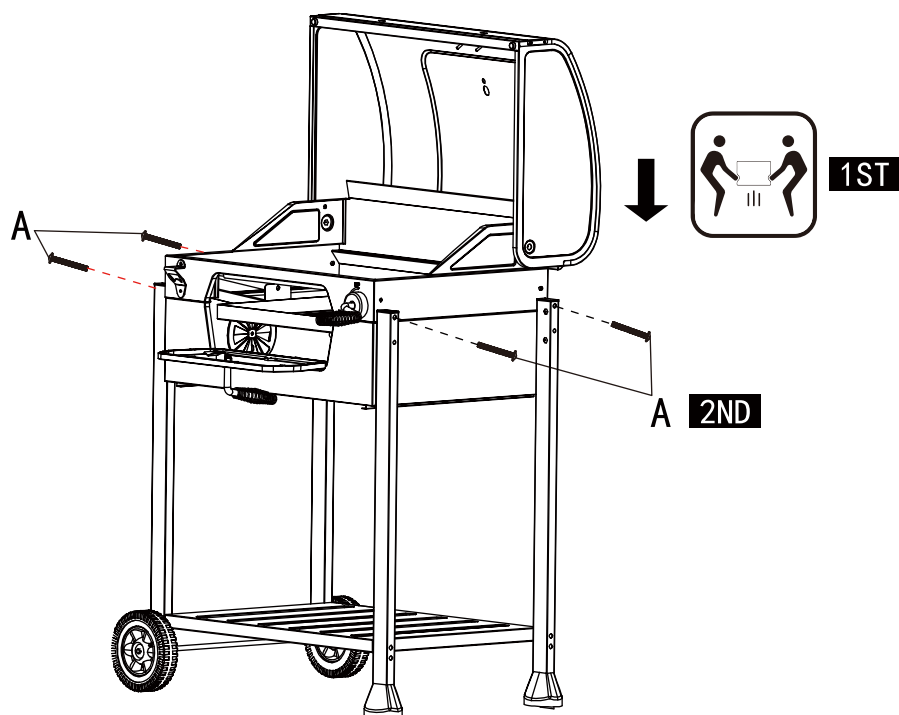

17 A  ×4

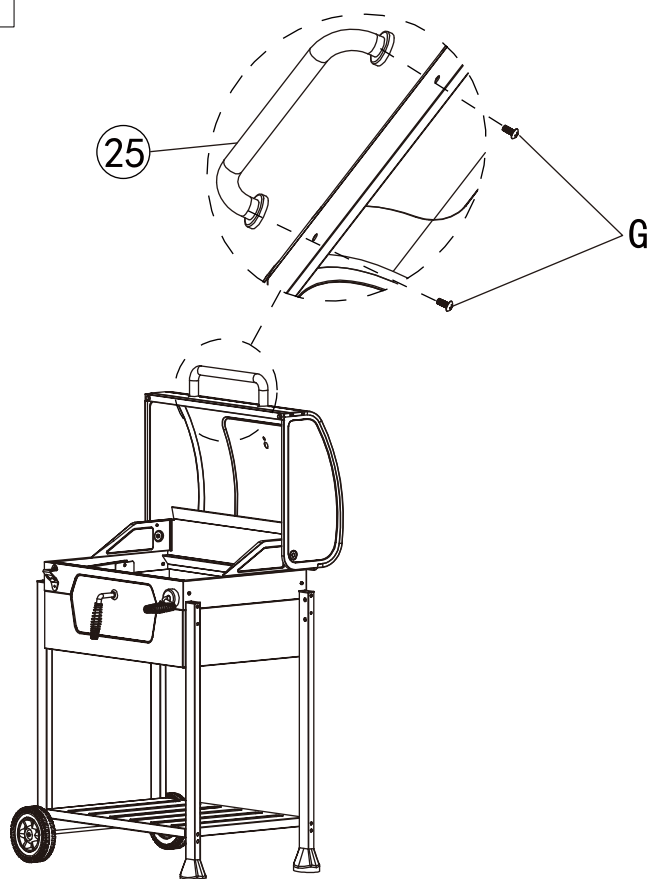

18 G  ×2



19	G		×2
	F		×2

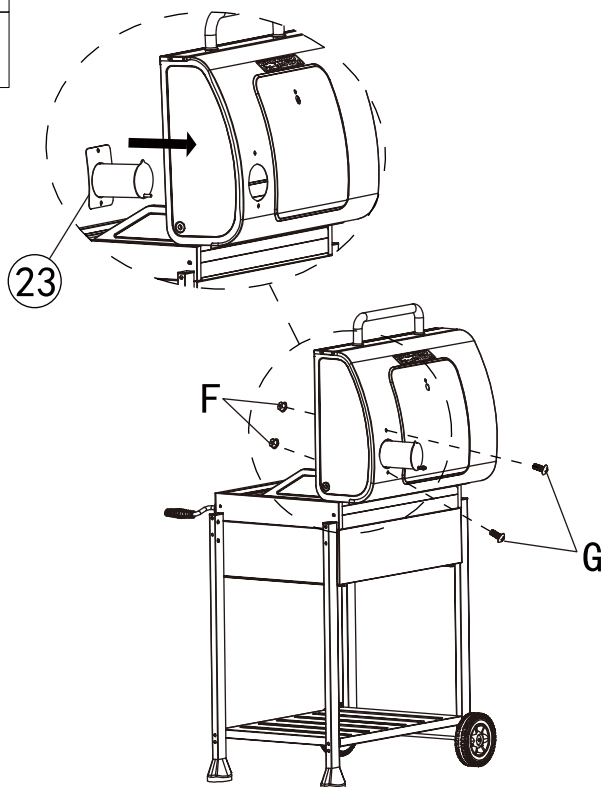

20

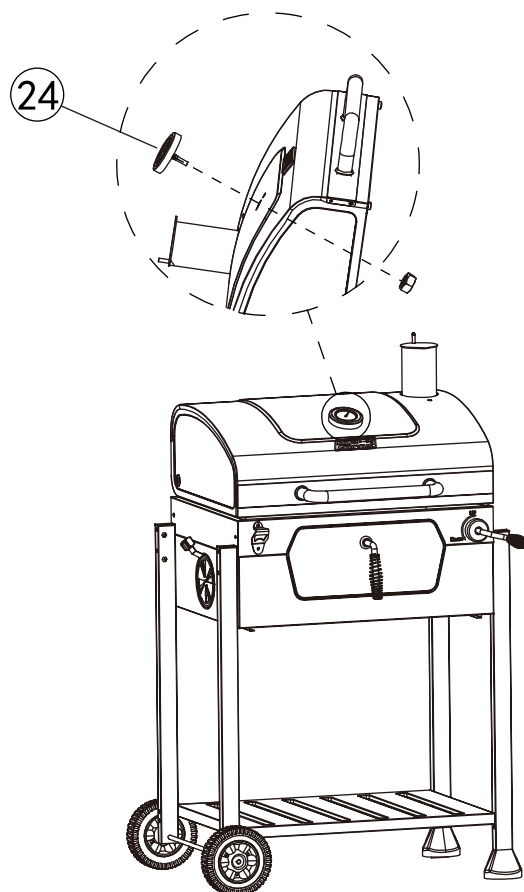

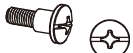

21 H  ×8

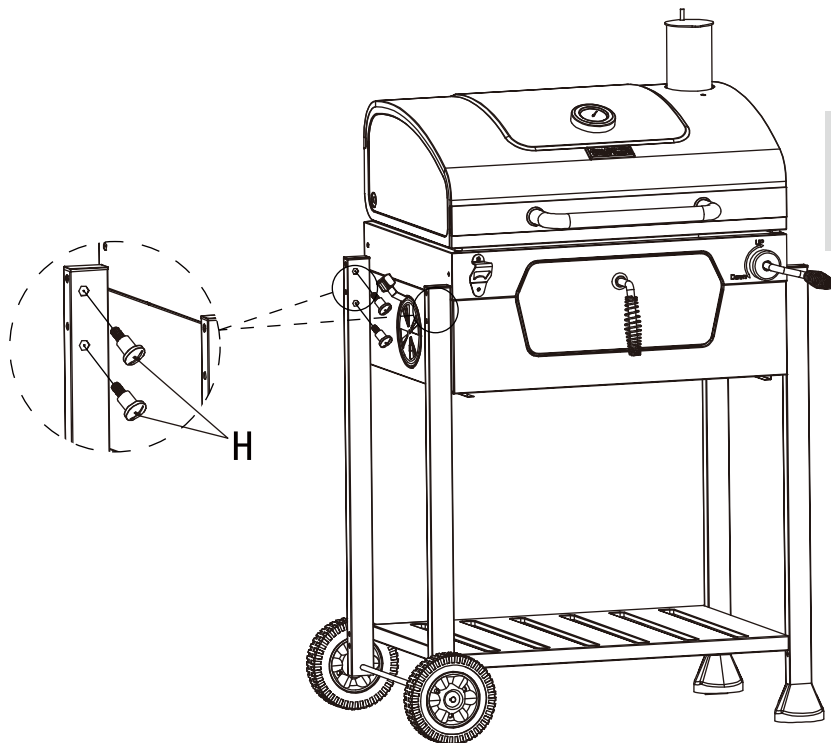

- Repeat for the other side.
- Repita esto paso para el otro lado.
- Répéter le étape pour l'autre côté.

22

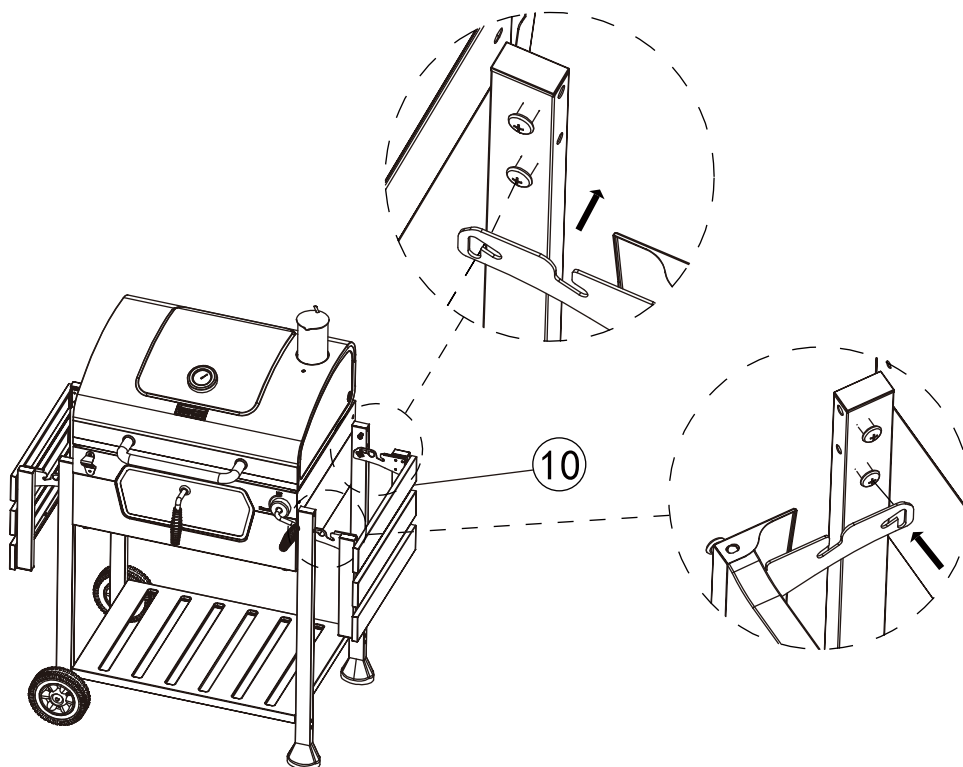

23

- Fodable side tables.
- Mesas auxiliares plegables.
- Tables d'appoint pliables.

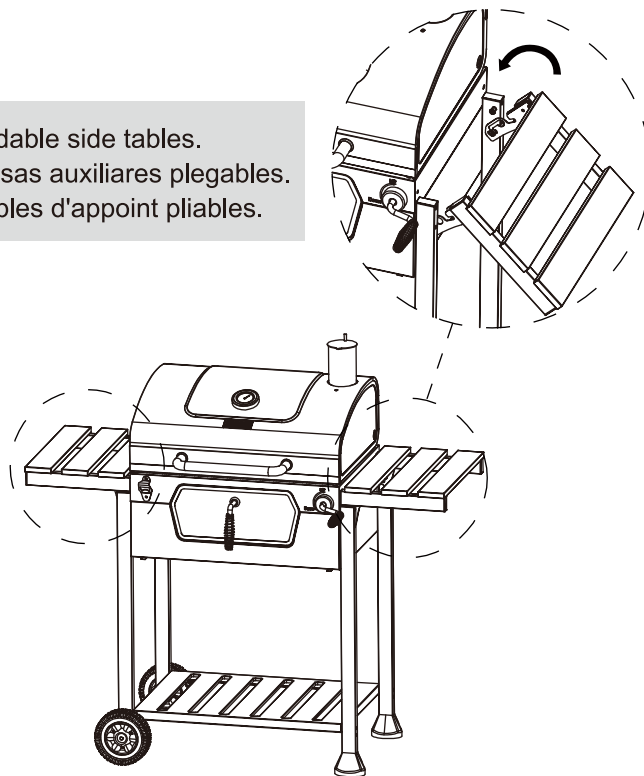

24

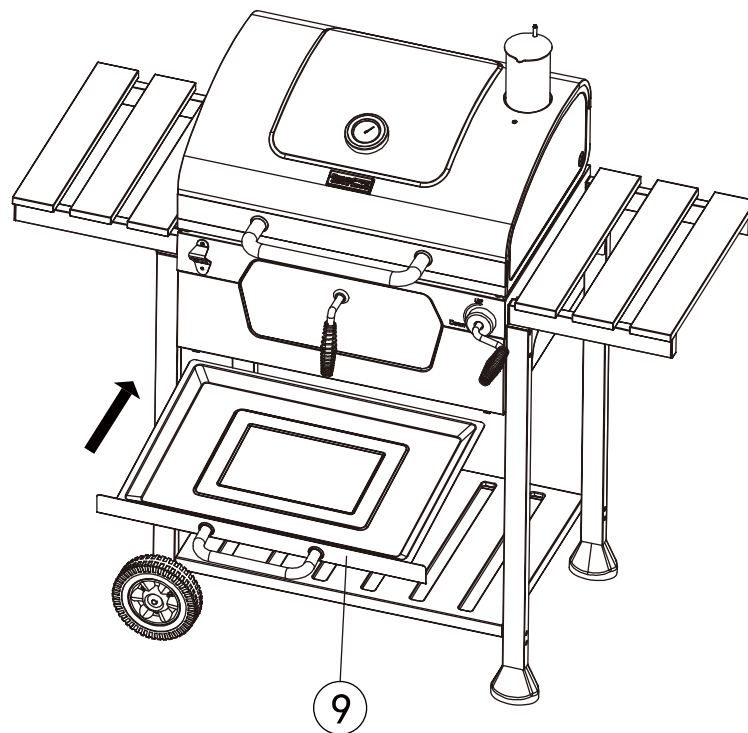

25

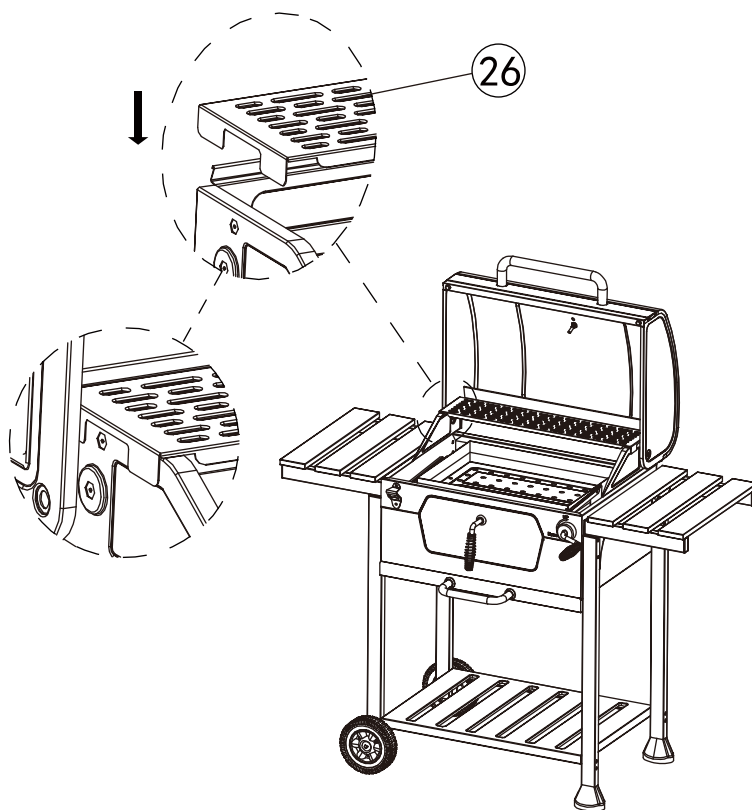

26

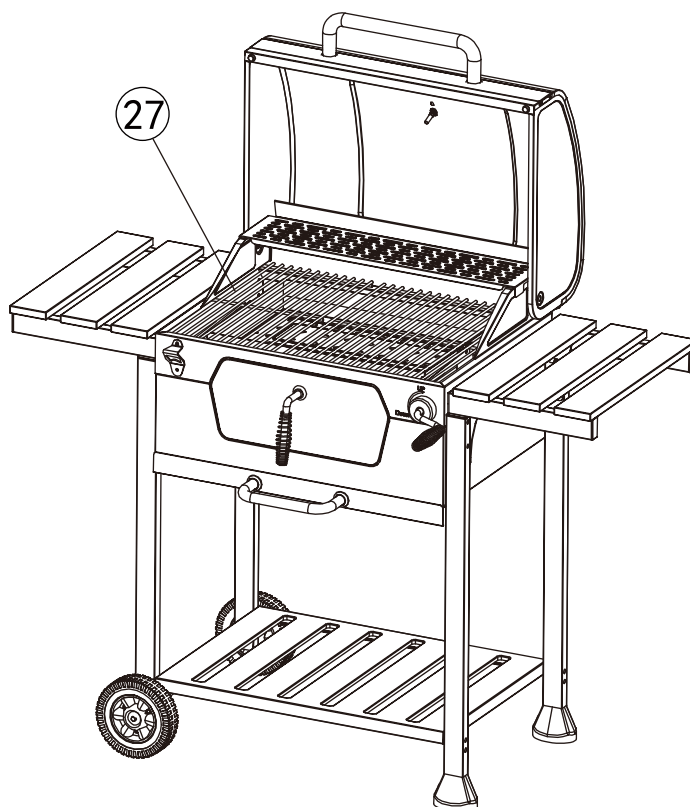

**Thank You  
For Choosing Us.**

**Any Problem!  
We Can Help!**

**Customer  
Service**

**1-800-618-6798**

**Monday to Friday ( 8:30 am - 5:30 pm EST )**

**[service@royalgourmetusa.com](mailto:service@royalgourmetusa.com)**